

RIO DP101/DP102 CAST IRON PUMP/VALVE COMBINATION



- * Rugged Cast Iron Construction
- * Interchangeable Parts
- * Optional Mounting
- * Optional Air shift actuation
- * High performance



◆ Dump Pump/Valve Ordering Specification

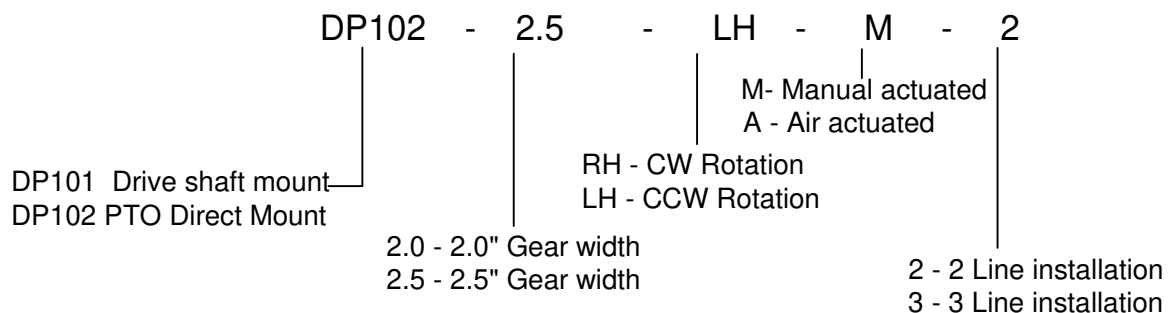

TECHNICAL DATA

Model series	Maximum psi	GPM @1800 RPM		MAXIMUM SPEED
		2"	2.5"	
DP101	2500	39	48	2400
DP102	2500	39	48	2400

DP101/102

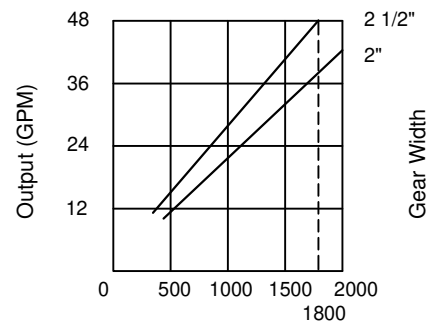

RIO offers a complete line of rugged cast iron pump / valve combination for the dump truck and trailer industry. Units are available for SAE-B PTO mounting (DP102) or remote drive shaft mounting (DP101). Units are supplied with full flow adjustable main relief valves to protect the pump and cylinder from overloading and shock loads. A three position valve assembly controls the raising, holding and lowering of a single acting cylinder, control valve can be cab operated using mechanical cable actuation or air shift control. Installation can be either 2 line or three line type using the sleeve supplied see page E4.2 .

RIO DP101/DP102 CAST IRON PUMP/VALVE COMBINATION



2-line installation

One line to cylinder, one line to the reservoir. For intermittent operation only.

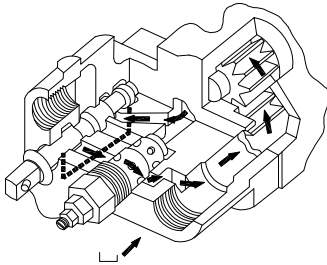

Spool in Neutral Position:

Oil recirculates internally.

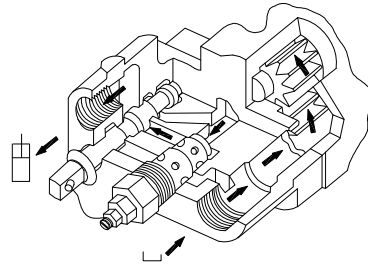

Spool in Raise Position:

Oil is routed through work port to raise the cylinder.

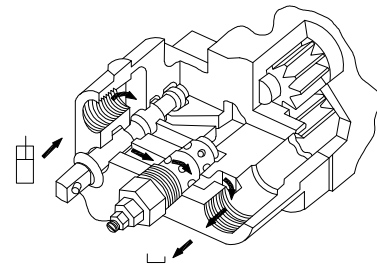

Spool in Lower Position:

Oil flows from the cylinder through the relief valve to return to tank.

3-line installation

One line to cylinder, two lines to the reservoir. For continuous or intermittent operation.

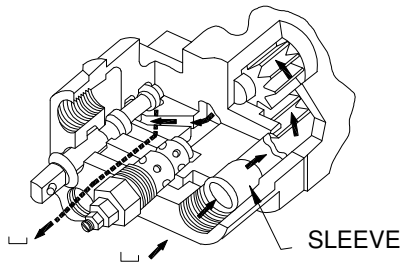

Spool in Neutral Position:

Oil circulates through the pump and returns to tank

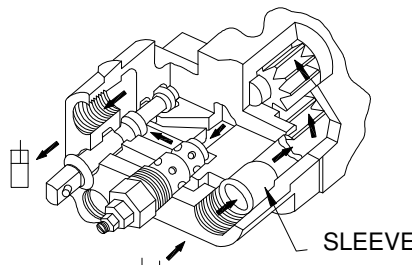

Spool in Raise Position:

Oil is routed through work port to raise the cylinder.

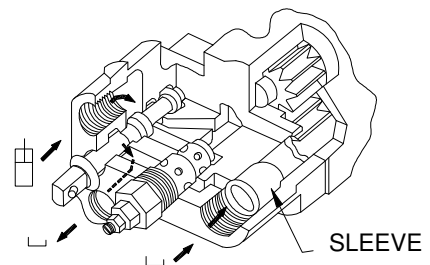

Spool in Lower Position:

Oil flows from the cylinder through the bottom port and returns to tank.

Note: Three line installation is recommended whenever possible by installing the sleeve supplied in the inlet port and connecting the optional return line to tank. This configuration maintains a lower operating temperature and a return line filter can be installed to filter return flow. Two line installations are for intermittent operation only.

RIO DP101/DP102 CAST IRON PUMP/VALVE COMBINATION

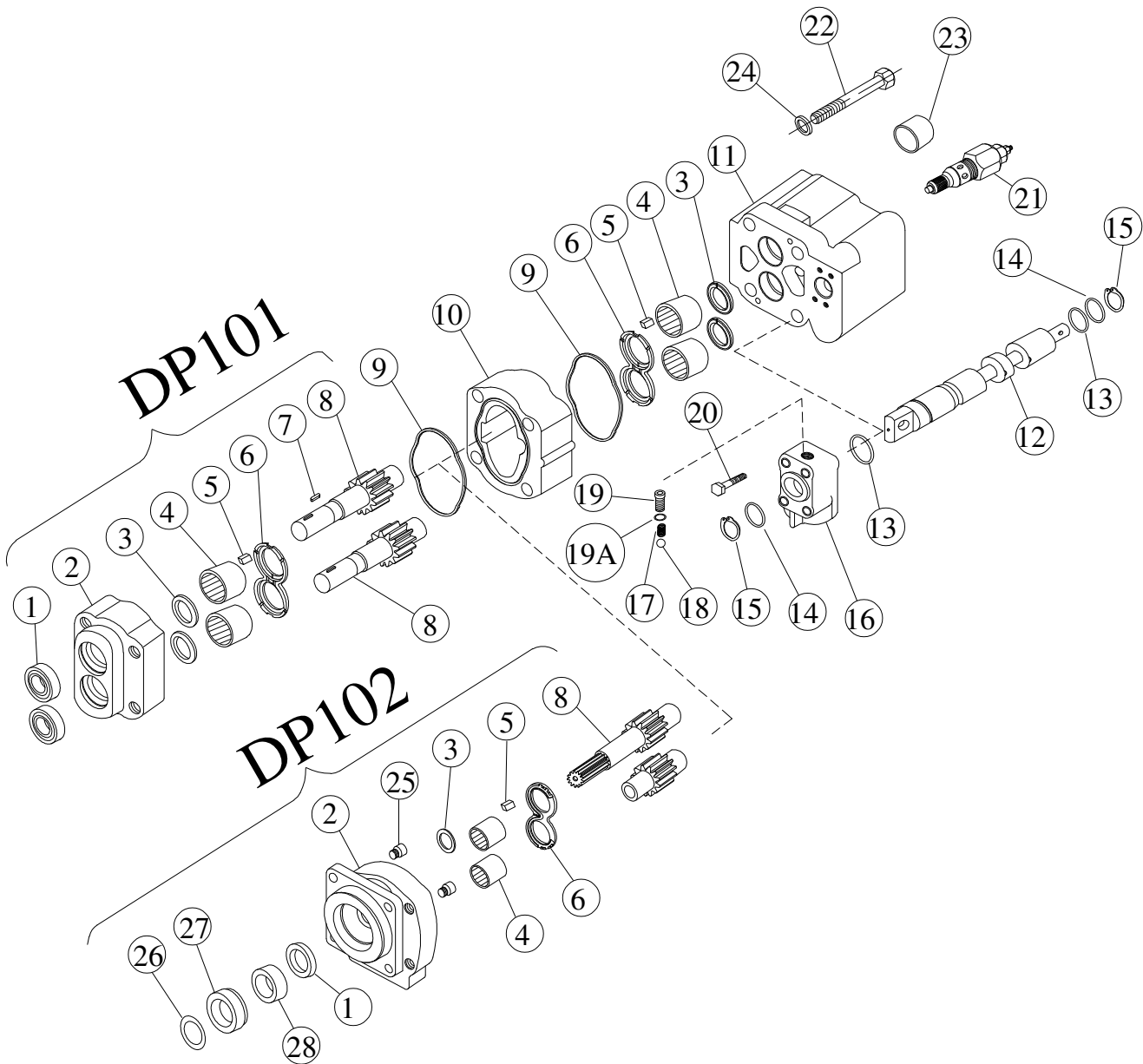

ITEM	DESCRIPTION	ITEM	DESCRIPTION	ITEM	DESCRIPTION
1	SHAFT SEAL	11	VAVLE HOUSING	20	CAP SCREWS
2	SHAFT END COVER	12	VALVE SPOOL	21	RELIEF VALVE ASSEMBLY
3	SHAFT RING SEALS	13	"O" RINGS	22	CAP CREWS
4	ROLLER BEARINGS	14	RETAINER RINGS	23	SLEEVE(OPTIONAL)
5	POCKET SEALS	15	SNAP RINGS	24	WASHERS
6	THRUST PLATES	16	VALVE CAP	25	CHECK ASSEMBLY
7	KEY	17	POPPET SPRING	26	SNAP RING
8	DRIVE HAFT&GEAR	18	STEEL BALL	27	SPACER
9	GASKET SEALS	19	DETENT RETAINER	28	RETAINER
10	GEAR HOUSING	19A	LOCAL WASHER		

RIO DP101/DP102 CAST IRON PUMP/VALVE DIMENSIONS



RIO DP101

GEAR WIDTH:
2.0" 2.5"
WEIGHT(lbs):
66 69

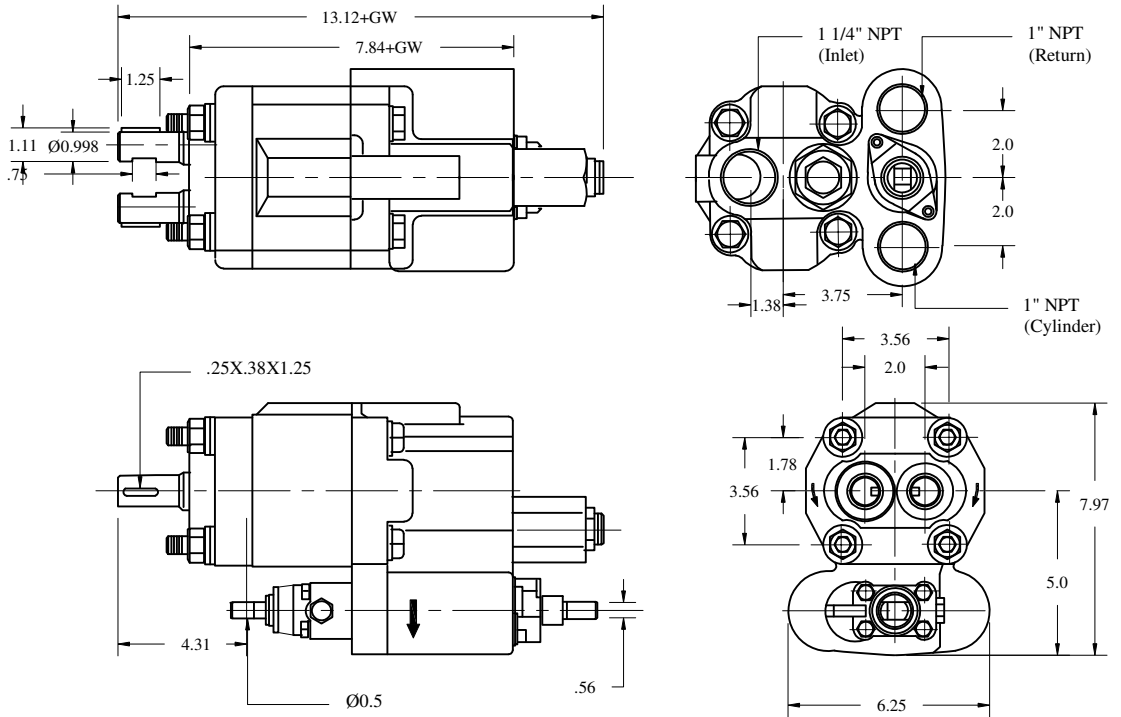

RIO DP102

GEAR WIDTH:
2.0" 2.5"
WEIGHT(lbs):
68 71

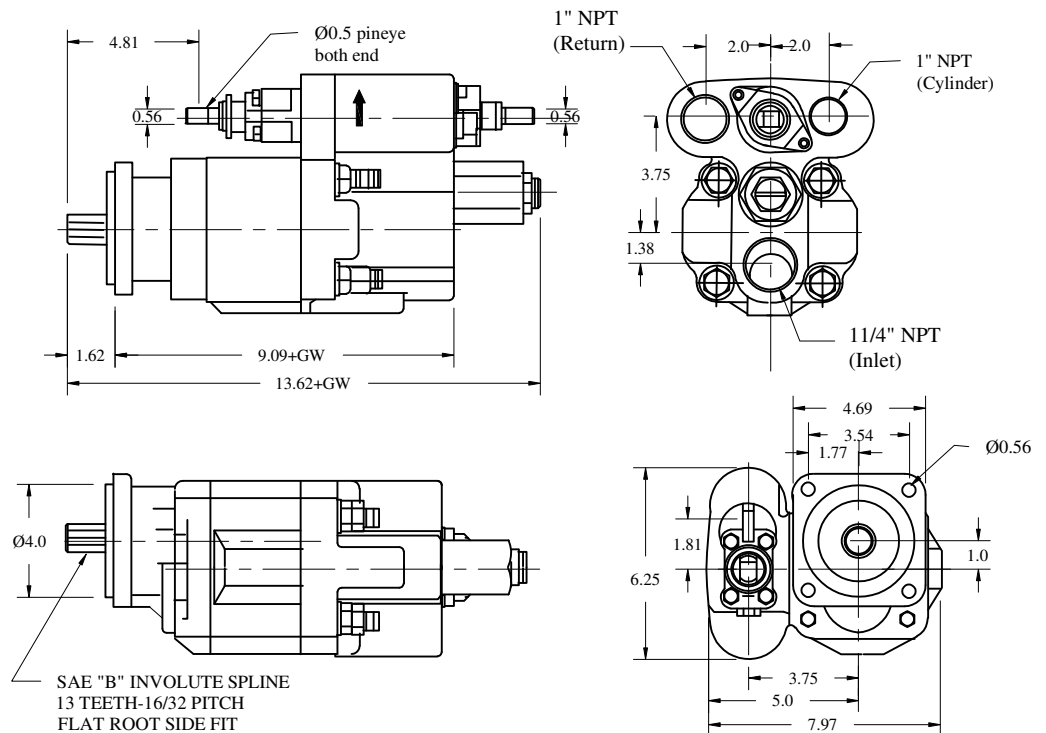

RIO C101/C102 AIR SHIFT

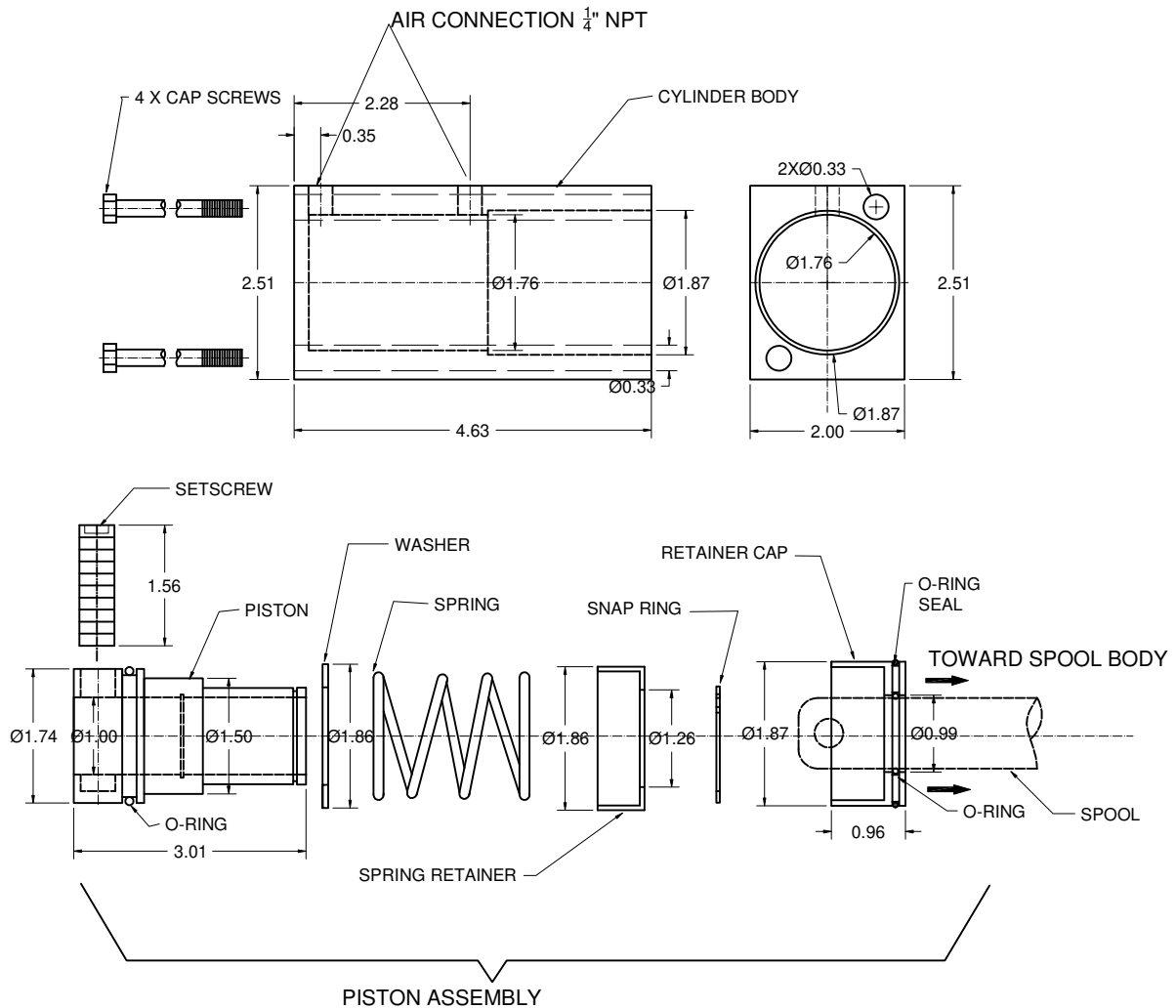

Air Shift Installation Instructions

- The Air shift mounts on IFP C101 / C102 Dump pumps in place of the detent end cap
- Prepare work area by assuring a clean work environment for assembly & disassembly of the Dump pump spool valve

Preparing Pump / Valve spool for air shift kit installation

- Remove snap ring and washer from valve spool
 - Remove the detent cap, spring and ball from the valves end cap
 - Remove four(4) cap screws and slide detent cap from the spool
- **DO NOT REMOVE "O" RING FROM VALVE HOUSING****

Installation of air shift kit

- Remove retainer cap
- Remove snap ring / spring retainer / spring / washer
- Slide piston assembly from the cylinder body
- Remove setscrew from piston assembly using 1/4" hex wrench
- Grease and slide Retainer Cap over valve spool with flat face of cap facing the spool body
- Assemble snap ring / spring retainer / spring / washer on piston
- Slide piston over valve spool and align and insert set screw attaching the piston to the spool
- Grease piston and O Rings
- Slide cylinder body over the piston assembly making sure not to damage the O Rings
- Secure the assembly using the 4 cap screws supplied